













LAWN & GARDEN TOOLS LAWN & GARDEN TOOLS

Part#	Application
<b>750-372</b>	 <p><b>Cylinder Deglazing Hone</b> Fits 1-1/2" thru 3" cylinders. No adapters needed to change size. Flexible shaft makes it easy to hone cylinders right on the Lawnmower. Size: 7-3/4" long. Comes complete with honing shoes</p>
<b>750-380</b>	 <p><b>Replacement Stones for Hone</b> Honing stones sold in set of (3), fine cut stones with cotter pin included.</p>
<b>750-315</b>	 <p><b>Piston Ring Expander</b> Capacity: 2" thru 4". Piston rings can be removed or installed without danger of breakage or distortion. No adjustments to make. Will expand all rings whether step-cut or diagonal cut.</p>
<b>750-323</b>	 <p><b>Piston Ring Compressor</b> Replaces B#S# 19230. A heavy duty small engine factory approved, ring compressor. Expandable from 1-3/4" thru 3-1/2" diameter, with 2" depth to take all the rings at once. Self locking heavy duty ratchet pawl prevents premature release. Double tension band, allen wrench included.</p>
<b>750-190</b>	 <p><b>Valve Spring Compressor</b> For air cooled 4 cycle engines with spring diameters up to 1-1/16". Provides plenty of clearance for removal and replacement of valve locks on small engines. Strongly built of hardened, tempered steel. Plated finish. Two jaws included for different size springs. Measures: 5-1/8" High X 3-3/8" deep.</p>
<b>750-174</b>	 <p><b>Valve Spring Compressor</b> Replaces B&amp;S# 19063. Fully adjustable steel jaws. For removing and replacing valve springs in small engines. Approved by engine manufacturers. Slender design lets you reach into smallest recess easily.</p>

Part#	Application
<b>750-182</b>	 <p><b>Valve Spring Compressor</b> For Briggs and Tecumseh engines. Removes and installs valve springs on all engines using self locking valve spring retainers. Hook end aligns valve spring retainer, notched end compresses valve spring.</p>
<b>750-257</b>	 <p><b>Valve Refacer Tool</b> Place tool in vise or bolt to bench. Valve clamped firmly in place and turned with hand crank. Special carboloy cutter makes job easy.</p>
<b>750-265</b>	 <p><b>Replacement Cutter Blades</b> Carbide cutter blade for above "ZIM" valve refacer tool.</p>
<b>750-224</b>	 <p><b>Valve Seating Tool</b> For hand grinding unseated valves. Includes (2) sizes of rubber cups - 15/16" and 1-1/16" diameter. Note: Use with our 750-216 "valve grinding compound" found on next page.</p>
<b>750-489</b>	 <p><b>Snap Ring Pliers</b> Convertible for either internal or external snap rings use. Fits 3/8" thru 7/8" snap rings. Automatic spring returns with adjustable stop.</p>
<b>750-901</b>	 <p><b>Oil Seal Puller</b> Removes cotter keys, oil seals, carburetor clips and has many other uses. Bits are hand forged alloy steel nickel chrome plated. Insulated handle. Measures: 7" overall length.</p>

LAWN & GARDEN TOOLS LAWN & GARDEN TOOLS





Part#	Application
<b>750-133</b> OEM#'s 19114 / 19244	 <p><b>Starter Clutch Remover</b> A real time saver to be used with 1" socket, any drive or 1/2" drive. Made of heavy gauge steel. Fits Briggs #19244. Also fits newest Briggs ratchets. (Used also to remove our 150-029 starter clutches)</p>
<b>750-067</b> OEM# 19167	 <p><b>Flywheel Holder and Wrench Kit</b> Used on 3 and 3-1/2 Hp engines. Briggs #19167. Holds flywheel securely for removal of B&amp;S starter clutches.</p>
<b>750-075</b>	 <p><b>Flywheel Holder and Wrench Kit</b> Used on 4 and 5 Hp engines. Holds flywheel securely for removal of B&amp;S starter clutches.</p>
<b>750-083</b>	 <p><b>Flywheel Holder and Wrench Kit</b> Used on 6, 7 and 8 Hp engines. Holds flywheel securely for removal of B&amp;S starter clutches.</p>
<b>750-091</b>	 <p><b>Flywheel Knocker (Puller)</b> Used on Briggs engines and others. Place over crankshaft and tap lightly to free flywheel.</p>
<b>750-109</b>	 <p><b>Flywheel Knocker (Puller)</b> Replaces Tecumseh #670103. Used on Tecumseh engines up to 3-1/2 Hp. Thread size: 7/16"</p>
<b>750-117</b>	 <p><b>Flywheel Knocker (Puller)</b> Replaces Tecumseh #670169. Used on Tecumseh engines up to 4 Hp and larger. Thread size: 1/2"</p>

Part#	Application
<b>750-125</b>	 <p><b>Flywheel Puller</b> Replaces Briggs# 19069 and 19165. Fits models 130000 thru 190000. Combines (2) Briggs pullers into one for universal use.</p>
<b>750-885</b>	 <p><b>Three Jaw Gear Puller - H.D.</b> Puller is drop-forged and features heat treated screws and floating screw centre points. Jaws are adjustable and reversible for application to all gear removal jobs. For use on items up to 6" diameter.</p>
<b>700-764</b>	 <p><b>Blade Balancer</b> This deluxe wall mounted "blade balancer" is a fast and accurate way to professionally balance Lawnmower blades. Magnetic collar holds any blade (with a centre hole up to 1-1/2" dia.), perfectly on centre. Tracking arm will indicate straightness of blade by matching blade cutting tips to end of tracking arm. <b>NOTE: May not be exactly as shown, magnet placement may be different</b></p>
<b>750-042</b>	 <p><b>Blade Balancer</b> This economy "blade balancer" is mainly used for quickly checking a Lawnmower blades balance after you have sharpened the blade. Specially designed to fit 99% of all centre holes. (Made of die-cast zinc)</p>
<b>750-034</b>	 <p><b>Blade Sharpener</b> This economy "blade sharpener" is used to sharpen Lawnmower blades, Tiller tines, Sickle bar cutters, Hoes and Scythes etc. Fits 1/4" and 3/8" drill chucks.</p>

LAWN & GARDEN TOOLS

LAWN & GARDEN TOOLS

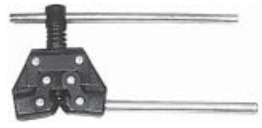
Part#	Application
<b>750-414</b>	
<b>Condenser Tool</b> This handy tool will compress the spring while you remove or attach primary wire.	
<b>750-422</b>	
<b>Electrical Crimping Pliers</b> The fast, easy and professional way to strip electrical wire. Used to strip automotive electrical wire.	
<b>752-408</b>	
<b>Digital Hour Meter</b> SenDEC - Small panel mount. Used on several riders. Fits all gasoline engines, regardless of number of cylinders, firing order or engine speed. <b>Replaces AYP# 169642, 177501, 110940X.</b>	
<b>752-949</b>	
<b>Tach / Hour Meter</b> Records actual running of engine. Non-erasable. Shows engine RPM's (Reads up to 9,000 RPM's). Alerts you to lube (grease) and Change oil (25 hour intervals). No battery required, triggered from the spark plug wire.	
<b>750-018</b>	
<b>Ignition Tester</b> To use disconnect spark plug lead from spark plug and attach it to the ignition tester. Clip ignition tester to most convenient ground on engine. Crank engine in the normal manner. If spark jumps across test plug, ignition is OK.	
<b>752-329</b>	
<b>In-Line Spark Tester</b> Connect one end to the spark plug lead, the other to the spark plug itself. Crank engine in normal manner. If the light in the tester glows brightly the ignition is OK. The intensity of the light is relative to the strength of the ignition. This tool is perfect for determining weak or sporadic spark on ignition systems that break down when they become hot.	

Part#	Application
<b>752-330</b> <b>NEW</b>	
<b>Ignition Tester</b> CheckSpark Engine Ignition Analyzer quickly and safely tests for proper spark on 2 stroke and 4 stroke engines. Eliminates guess work. 1 of 3 LED's will accurately indicate the condition of ignition system. Tests, proper voltage, high voltage, low voltage, no voltage. One person, hands free operation, just clip on the sparkplug wire and crank. Patented gripper hook. (For other ignition testers see our 750-018 and 752-329).	
<b>751-180</b>	
<b>Wireless Tachometer</b> A hand held precision instrument that accurately determines R.P.M. on 2 & 4 cycle, single cylinder engines. No direct connection required. Just hold built in antenna near spark plug or high tension lead. Selector switch gives 0 thru 5000 R.P.M. - (low scale) or 0 thru 15000 R.P.M. (high scale). Unit has solid state electronics.	
<b>750-455</b>	
<b>Z - Bender</b> Bends both .054" and .072" inner wire. Used to put the " Z " bend in throttle control inner wire.	
<b>750-430</b>	
<b>Roller Chain Breaker</b> Adapts to #35 thru #50 roller chains.	
<b>750-448</b>	
<b>Roller Chain Holder / Puller</b> For #35 thru #60 roller chains. Helps put on a chain at right tension. Also works with bicycle chains.	
<b>750-810</b>	
<b>Spark Plug Hole Tap</b> 14 mm and 18 mm "chaser" services practically all makes and models. Cleans threads of carbon, corrosion and metal. 13/16" hex has neoprene band to hold "chaser" firmly in place inside a deep style socket.	

LAWN & GARDEN TOOLS

LAWN & GARDEN TOOLS

Part#	Application
<b>750-026</b> <b>Spark Plug Wrench</b> Fits 3/4" hex shorty plugs and 13/16" hex standard plugs.	
<b>752-111</b> <b>4 - Way Valve Stem Repair Tool</b> To install and remove valve stem cores.	
<b>750-893</b> <b>Gasket Scraper</b> Measures: 11" overall, 8" long shaft with a 1" face. Nickel chrome plated with insulate handle.	
<b>750-547</b> <b>Feeler Gauge</b> 17 straight blades measuring 1/4" W X 1-3/4" L. Handy size for use in restricted areas. Tempered carbon steel with easy to read decimal sizes and metric equivalents permanently etched on each.	
<b>752-246</b> <b>Nylon Recoil Air Hose</b> Measures: 1/4" ID X 25 ft length. Up to 200 P.S.I. standard fitting with spring guard. For use with all air tools.	
<b>750-158</b> <b>Starter Spring Rewind Tool</b> Replaces Briggs# 19409. This tool inserts into the Briggs starter pulley. It aids you in rewinding and maintaining tension on the starter spring.	
<b>752-000</b> <b>J B WELD</b> A cold weld compound. It repairs, fills and bonds the following: iron, steel, copper, aluminum, brass, bronze, pewter, wood, porcelain, ceramic and plastic. (Full box contains 6 sets of 2) (Priced and sold individually - 2 tubes per set)	

Part#	Application
<b>750-919</b> <b>Crankshaft Holder Wrench</b> Makes ignition and valve work easier. Turns crankshaft with key in or out after flywheel is removed. Prevents damage to crankshaft from improper use of pliers, wrenches, etc.	
<b>750-331</b> <b>Ridge Reamer</b> For small motors range 2" thru 3". To do a correct ring job, the upper ridge in the cylinder must be removed. Two minutes time will remove the ridge and will stop recurring trouble. (For a replacement cutter for the above ridge reamer order part# 750-333)	
<b>750-356</b> <b>Piston Groove Cleaner</b> An inexpensive tool for cleaning grooves on pistons up to 5-1/2" diameter. Easy to operate, nothing to adjust. Five cleaning blades made from hardened and tempered steel. Width: 5/64", 3/32", 1/8", 5/32" and 3/16". To change position of blades simply loosen the screw and turn blade to correct groove size required. (For a replacement cutter for our above groove cleaner order part# 750-358)	
<b>753-000</b> <b>Heli Coil Insert Tool - 14 mm</b> This tool was designed by Heli Coil to aid in the insertion of their 14 mm spark plug coils. It compresses the coil, allowing it to thread into the tapered hole. This results in a snug and secure fit.	
<b>733-610</b> (old# 5523-10) <b>Heli Coil Thread Repair Kit - 10 X 1.0 mm</b> This spark plug kit is recommended for replacement of striped threads in spark plug ports. Kit includes: plastic case, piloted tap, installation tool and (24) 10 mm X 1/2" reach insert coils.	

METRIC KITS

Part#	Application
-------	-------------

THREAD REPAIR KITS



METRIC "KITS"

Part#	Thread Size	Insert Qty.	Fix-a Thread Number
<b>733-043</b>	M4 X 0.7	10	35045
<b>733-053</b>	M5 X 0.8	10	35055
<b>733-063</b>	M6 X 1	10	35065
<b>733-073</b>	M7 X 1	10	35075
<b>733-083</b>	M8 X 1.25	10	35085
<b>733-093</b>	M10 X 1.25	10	37100
<b>733-122</b>	M12 X 1.25	10	38125
<b>733-518</b>	M18 X 1.5	5	38185

**Kit Includes:** Insertion / Tang break off tool, Tap, Inserts and easy to follow instruction sheet.

THREAD INSERTS



METRIC "INSERTS"

Part#	Thread Size	Insert Qty.	Fix-a Thread Number
<b>732-043</b>	M4 X 0.7	10	25043
<b>732-053</b>	M5 X 0.8	10	25053
<b>732-063</b>	M6 X 1	10	25063
<b>732-073</b>	M7 X 1	10	25073
<b>732-083</b>	M8 X 1.25	10	25083
<b>732-093</b>	M10 X 1.25	10	27103
<b>732-103</b>	M10 X 1.5	10	25103
<b>732-122</b>	M12 X 1.25 (1/2" reach)	10	28122
<b>732-123</b>	M12 X 1.25 (3/4" reach)	10	28123

**Inserts:** Length = 1.5 times the diameter. Packaged in plastic bags with part numbers & sizes

METRIC KITS continued

Part#	Application
-------	-------------

THREAD REPAIR KITS

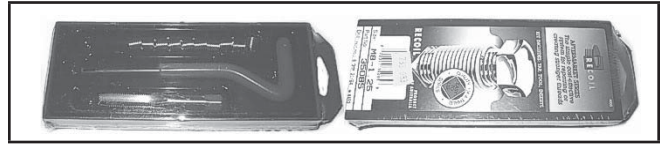

UNC / UNF "KITS"

Part#	Thread Size	Insert Qty.	Fix-a Thread Number
<b>733-010</b>	10-32	10	34605
<b>733-008</b>	5/16-24 (W.Q.L)	10	34055
<b>733-009</b>	3/8-24 (W.Q.L)	10	34065
<b>733-004</b>	8-32	10	33085
<b>733-005</b>	10-24	10	33605
<b>733-006</b>	12-24	10	33625
<b>733-001</b>	1/4-20	10	33045
<b>733-002</b>	5/16-18	10	33055
<b>733-003</b>	3/8-16	10	33065

**Kit Includes:** Insertion / Tang break off tool, Tap, Inserts and easy to follow instruction sheet.

THREAD INSERTS



UNC / UNF "INSERTS"

Part#	Thread Size	Insert Qty.	Fix-a Thread Number
<b>732-010</b>	10-32	10	24603
<b>732-007</b>	1/4-28	10	24043
<b>732-008</b>	5/16-24	10	24053
<b>732-009</b>	3/8-24	10	24063
<b>732-004</b>	8-32	10	23583
<b>732-005</b>	10-24	10	23603
<b>732-006</b>	12-24	10	23623
<b>732-001</b>	1/4-20	10	23043
<b>732-002</b>	5/16-18	10	23053
<b>732-003</b>	3/8-16	10	23063

**Inserts:** Length = 1.5 times the diameter. Packaged in plastic bags with part numbers & sizes

THREAD REPAIR KIT

Part#	Application
-------	-------------

14mm SPARK PLUG KITS

**733-614**

**"Deluxe"**

**Spark Plug Kit**

Recommended for replacement of stripped threads in spark plug ports. Kit includes: steel case, piloted tap, installation tool and (5) each of the following inserts-14 mm X 3/8" & 3/4" reach (Old Fix-a-Thread #38145). (May not be exactly as shown)



14 mm INSERTS only

Part#	Thread Size	Insert Length	Insert Qty.	Fix-a-Thread#
<b>732-448</b>	14mm X 1.25	3/8"	10	28148
<b>732-447</b>	14mm X 1.25	7/16"	10	28147
<b>732-449</b>	14mm X 1.25	1/2"	10	28149
<b>732-440</b>	14mm X 1.25	3/4"	10	28140

(Priced and Sold in Multiples of 10).

CRANKSHAFT STRAIGHTENER

**751-032**

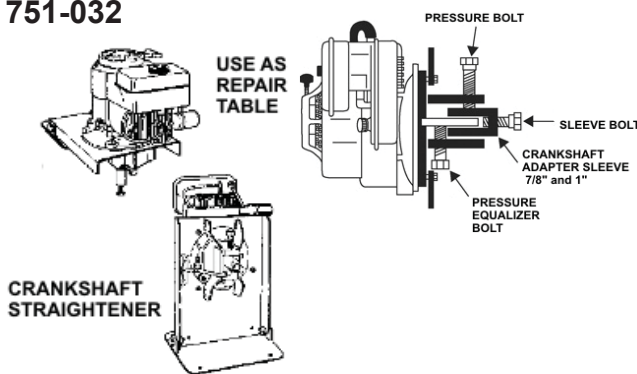

**Crankshaft Straightener**

Mighty Midget "Deluxe" Crankshaft Straightener and also combination work table which can be bolted solidly to your work bench when repairing engines. This crankshaft straightener will make you money fast and easy as you can straighten a crankshaft and also repair an engine without removing it from the straightener. Precision control and pressure equalizer lets you straighten 98% of bent crankshafts in the engine.

Includes:

- (1) 751-065 adaptor sleeve (7/8")
- (1) 751-081 adaptor sleeve (1")
- (1) 419-325 pressure bolt (5/8"-20)
- (1) 419-333 sleeve bolt (1/2"-20)
- (1) 419-317 pressure equalizer bolt (1/2"-20)

REPLACEMENT PARTS

Part#	Application
-------	-------------

**419-317**

**Pressure Equalizer Bolt**

(1/2"-20 X 1-3/4" L) - Replacement bolt for use on our 751-032 Crankshaft Straightener.



**419-325**

**Pressure Bolt**

(5/8"-20 X 1-3/4" L) Replacement bolt for use on our 751-032 Crankshaft Straightener.



**419-333**

**Sleeve Bolt**

(1/2"-20) - Replacement bolt for use on our 751-032 Crankshaft Straightener.



**751-099**

**Adaptor Sleeve**

(3/4" shaft) Replacement sleeve for Miget Racer engines. For use with our 751-032 crankshaft straightener



**751-065**

**Adaptor Sleeve**

(7/8" shaft) - Replacement sleeve for 2 and 4 cycle Lawnmower engines. For use with our 751-032 crankshaft straightener



**751-081**

**Shaft Protector Sleeve**

(1" stepped shaft) - Replacement sleeve for 2 & 4 cycle and Quantum Lawnmower engines. For use with our 751-032 crankshaft straightener



NOTES: